

GENERAL INFORMATION

IMPORTANT INFORMATION	GI- 2
BASIC ASSUMPTIONS	GI- 2
SAFETY RISK	GI- 2
POSSIBLE LOSS OF WARRANTY	GI- 2
WARNING ON LUBRICANTS AND GREASES	GI- 2
HOW TO USE THIS MANUAL	GI- 3
PREPARATION	GI- 3
REPAIR PROCEDURE	GI- 3
SYMBOLS	GI- 4
NOTES, CAUTIONS, AND WARNINGS	GI- 4
FUNDAMENTAL PROCEDURES	GI- 4
PROTECTION OF VEHICLE	GI- 4
A WORD ABOUT SAFETY	GI- 5
PREPARATION OF TOOLS AND MEASURING EQUIPMENT	GI- 5
SPECIAL TOOLS	GI- 5
REMOVAL OF PARTS	GI- 5
DISASSEMBLY	GI- 5
ASSEMBLY	GI- 6
ADJUSTMENTS	GI- 7
RUBBER PARTS AND TUBING	GI- 7
JACK AND SAFETY STAND POSITIONS	GI- 8
VEHICLE LIFT (2-SUPPORT TYPE) POSITIONS	GI- 8
TOWING	GI- 9
IDENTIFICATION NUMBER LOCATIONS	GI-10
UNITS	GI-10
ABBREVIATIONS	GI-10
CAUTION	GI-11
INSTALLATION OF MOBILE TWO-WAY RADIO SYSTEM	GI-11
REMOVAL OF IGNITION KEY ON AUTOMATIC TRANSMISSION MODEL	GI-11
ELECTRICAL TROUBLESHOOTING TOOLS	GI-12
CAUTION WITH ELECTRICAL PARTS	GI-12

IMPORTANT INFORMATION**BASIC ASSUMPTIONS**

This workshop manual assumes that you have certain special tools that are necessary for the safe and efficient performance of service operations on Mazda vehicles and that you know how to use them properly. It also assumes that you are familiar with automobile systems and basic service and repair procedures. You should not attempt to use this manual unless these assumptions are correct and you understand the consequences described below.

SAFETY RISK

This manual contains certain notes, warnings, etc., which you should carefully read and follow in order to eliminate the risk of personal injury to yourself or others and the risk of improper service which may damage the vehicle or render it unsafe. The fact that there are no such notes, etc., with respect to any specific service method does not mean that there is no possibility that personal safety or vehicle safety will be jeopardized by the use of incorrect methods or tools.

POSSIBLE LOSS OF WARRANTY

The manufacturer's warranty on Mazda vehicles and engines can be voided if improper service or repairs are performed by persons other than an authorized Mazda dealer.

WARNING ON LUBRICANTS AND GREASES

Avoid all prolonged and repeated contact with mineral oils, especially used oils. Used oils contaminated during service (e.g., engine sump oils) are more irritating and more likely to cause serious effects, including skin cancer, in the event of gross and prolonged skin contact.

Wash skin thoroughly after work involving oil.

Protective hand cleaners may be of value provided they can be removed from the skin with water. Do not use gasoline, paraffin, or other solvents to remove oil from the skin.

Lubricants and greases may be slightly irritating to the eyes.

Repeated or prolonged skin contact should be avoided by wearing protective clothing if necessary. Particular care should be taken with used oils and greases containing lead. Do not allow work clothing to be contaminated with oil. Dry clean or launder such clothing at regular intervals.

06UGIX 002

HOW TO USE THIS MANUAL

PREPARATION

PREPARATION points out the needed **Special Service Tool (SST)** for the service operation that it proceeds. Gather all necessary **SST** before beginning work.

Example:

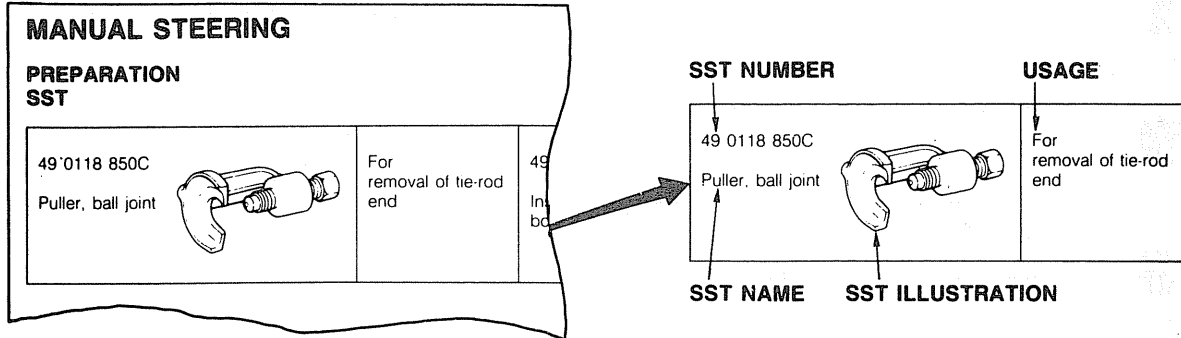

05UGIX-003

REPAIR PROCEDURE

1. Most repair operations begin with an overview illustration. It identifies the components, shows how the parts fit together, and visual parts inspections. If a damaged or worn part is found, repair or replace it as necessary.
2. Expendable parts, tightening torques, and symbols for oil, grease, and sealant are shown in the overview illustration.
3. Pages related to service procedures are shown under the illustration. Refer to this information when servicing the related part.

Example:

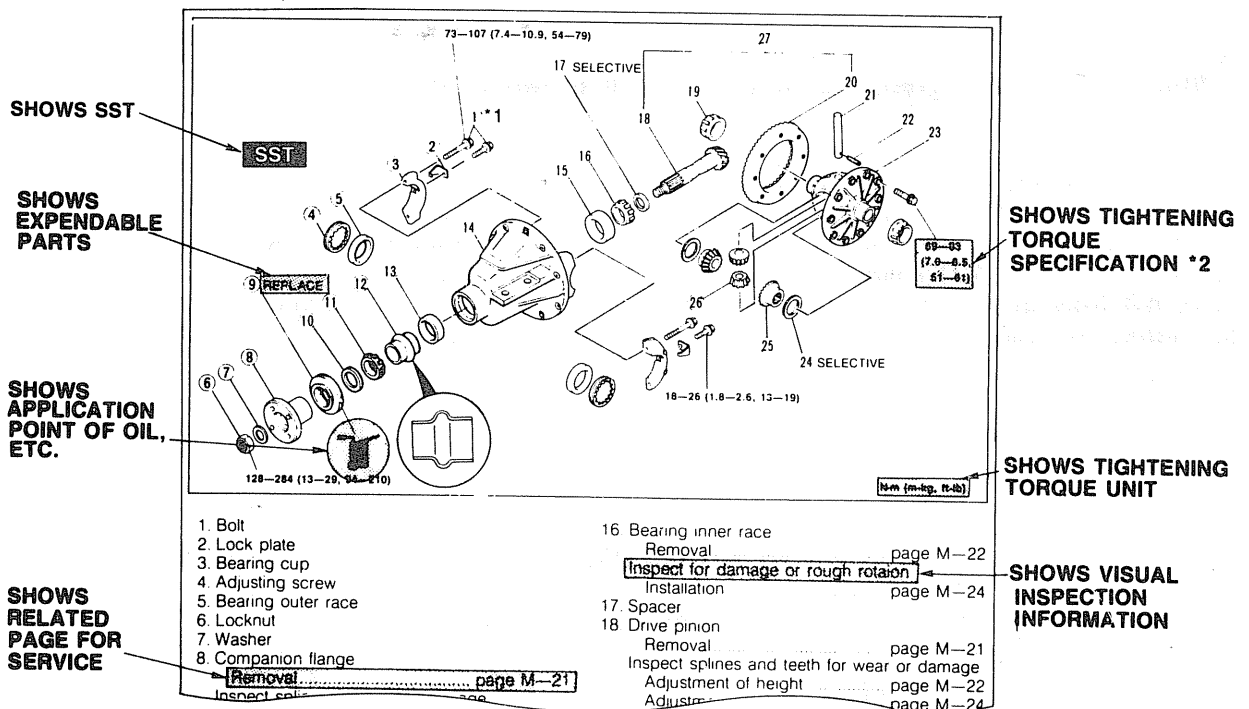







*1: The numbering (ex. ①) shown service procedure.

*2: Units shown in Nm (m-kg, ft-lb) unless otherwise specified.

SYMBOLS

There are six symbols indicating oil, grease, and sealant. These symbols show the points of applying such materials during service.

Symbol	Meaning	Kind
	Apply oil	New engine oil or gear oil as appropriate
	Apply brake fluid	Only brake fluid
	Apply automatic transmission fluid	Only ATF
	Apply grease	Appropriate grease
	Apply sealant	Appropriate sealant
	Apply petroleum jelly	Appropriate petroleum jelly

05UGIX-005

Note

- When special oil or grease is needed, this is shown in the illustration.

NOTES, CAUTIONS, AND WARNINGS

As you read through the procedures, you will come across NOTES, CAUTIONS, and WARNINGS. Each one is there for a specific purpose. **NOTES** give you **added information** that will help you to complete a particular procedure. **CAUTIONS** are given to prevent you from making an error that could **damage the vehicle**. **WARNINGS** remind you to be especially careful in those areas where carelessness can cause **personal injury**. The following list contains some general WARNINGS you should follow when you work on a vehicle.

9MUGIX-036

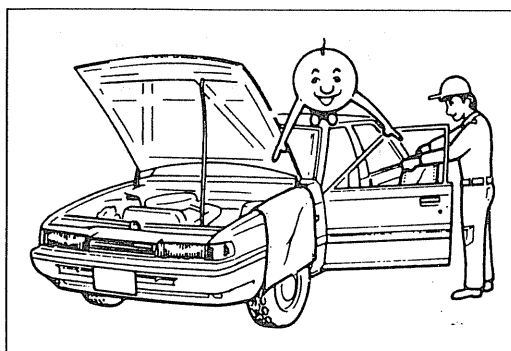

05UGIX-006

FUNDAMENTAL PROCEDURES**PROTECTION OF VEHICLE**

Always be sure to cover fenders, seats, and floor areas before starting work.

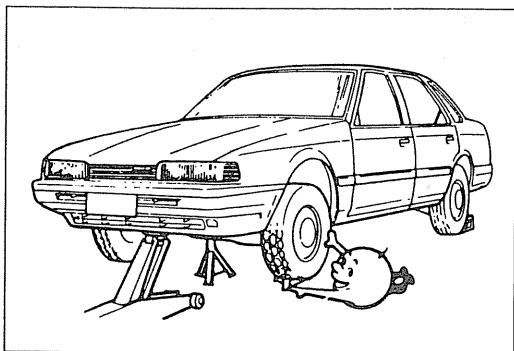

47U0GX-003

A WORD ABOUT SAFETY

The following precautions must be followed when jacking up the vehicle.

1. Block wheels.
2. Use only specified jacking positions.
3. Support vehicle with safety stands (rigid racks).

Start the engine only after making certain the engine compartment is clear of tools and people.

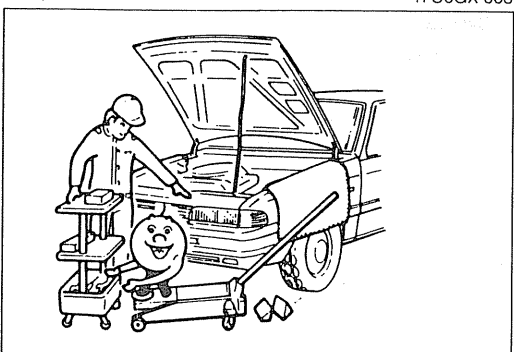

47U0GX-004

PREPARATION OF TOOLS AND MEASURING EQUIPMENT

Be sure that all necessary tools and measuring equipment are available before starting any work activity.

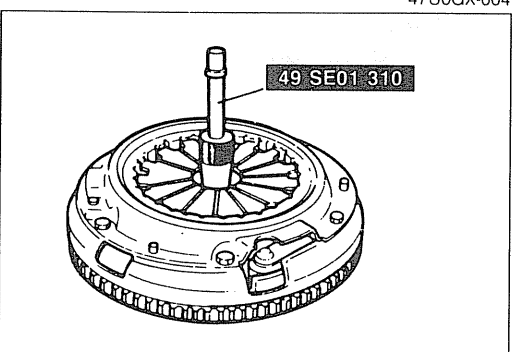

47U0GX-005

SPECIAL TOOLS

Use special tools when they are required.

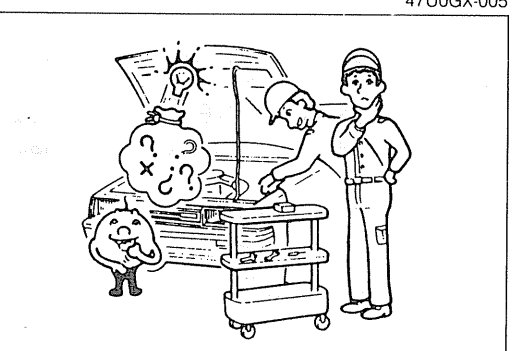

47U0GX-006

REMOVAL OF PARTS

While correcting a problem, try also to determine its cause. Begin work only after first learning which parts and subassemblies must be removed and disassembled for replacement or repair.

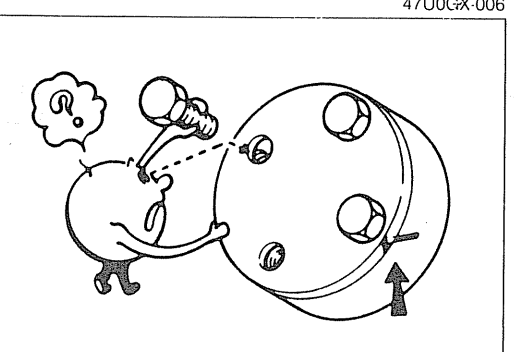

47U0GX-007

DISASSEMBLY

If the disassembly procedure is complex, requiring many parts to be disassembled, all parts should be disassembled in a way that will not affect their performance or external appearance, and be identified so that reassembly can be performed easily and efficiently.

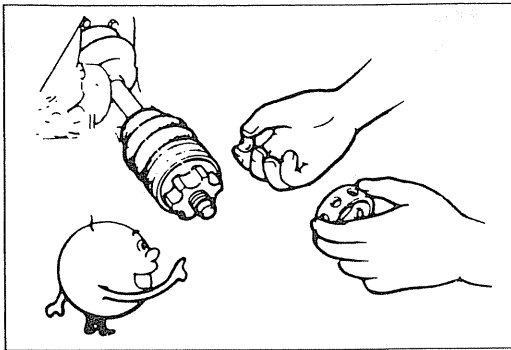

06UGIX-004

1. Inspection of parts

When removed, each part should be carefully inspected for malfunctioning deformation, damage, and other problems.

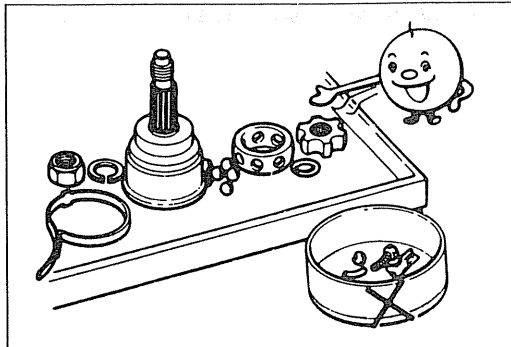

47U0GX-009

2. Arrangement of parts

All disassembled parts should be carefully arranged for reassembly.

Be sure to separate or otherwise identify the parts to be replaced from those that will be reused.

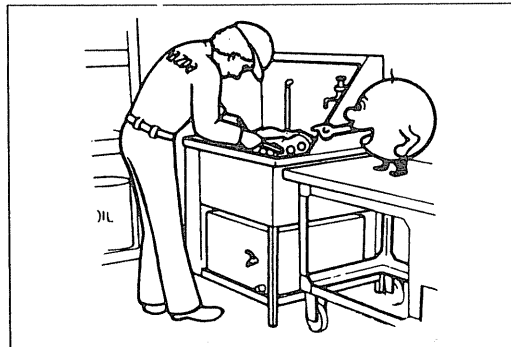

47U0GX-010

3. Cleaning parts for reuse

All parts to be reused should be carefully and thoroughly cleaned in the appropriate method.

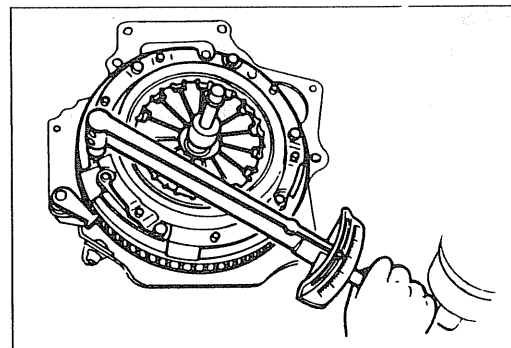

06UGIX-005

ASSEMBLY

Standard values, such as torques and certain adjustments, must be strictly observed in the reassembly of all parts. Refer to STANDARD BOLT AND NUT TIGHTENING TORQUE in Section TD for tightening torques not mentioned in the main text.

If removed, these parts should be replaced with new ones:

- | | |
|--------------|-----------------|
| 1. Oil seals | 4. Lock washers |
| 2. Gaskets | 5. Cotter pins |
| 3. O-rings | 6. Nylon nuts |

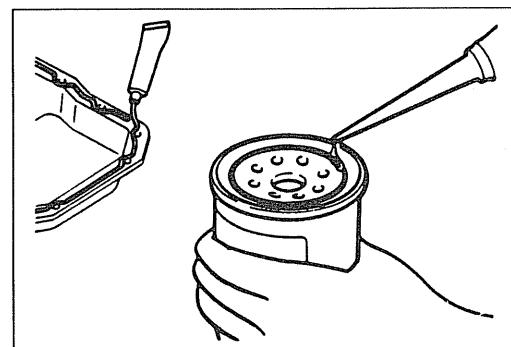

06UGIX-006

Depending on location:

1. Sealant should be applied to gaskets
2. Oil should be applied to the moving components of parts
3. Specified oil or grease should be applied at the prescribed locations (oil seals, etc.) before assembly.

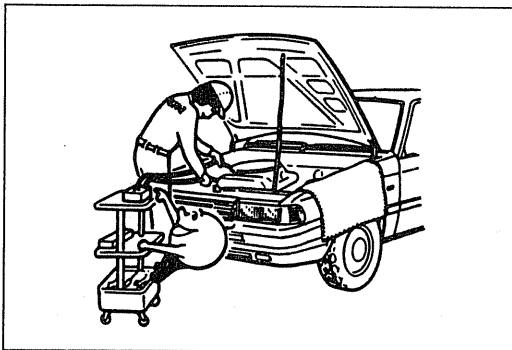

06UGIX-007

ADJUSTMENTS

Use suitable gauges and/or testers when making adjustments.

GI

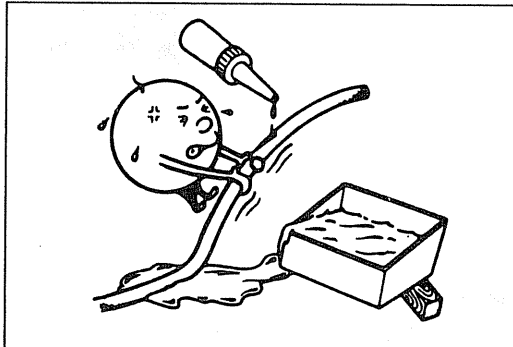

06UGIX-008

RUBBER PARTS AND TUBING

Prevent gasoline or oil from getting on rubber parts or tubing.

GI JACK AND SAFETY STAND POSITIONS, VEHICLE LIFT (2-SUPPORT TYPE) POSITIONS

JACK AND SAFETY STAND POSITIONS

FRONT END

Jack position:

At the center of the crossmember

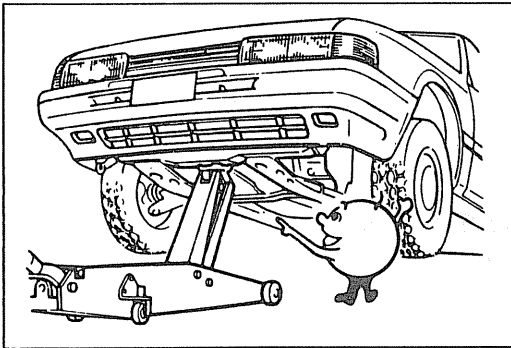

16UGIX-003

Safety stand positions:

On both sides of the body frame

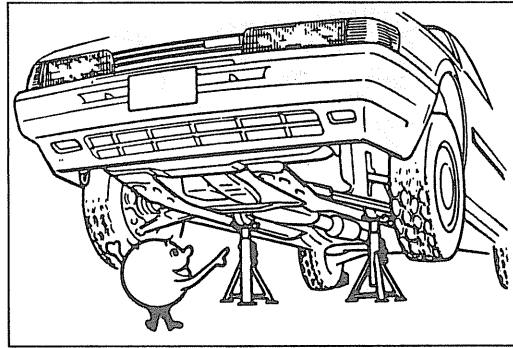

47U0GX-017

REAR END

Jack position:

At the center of the rear crossmember

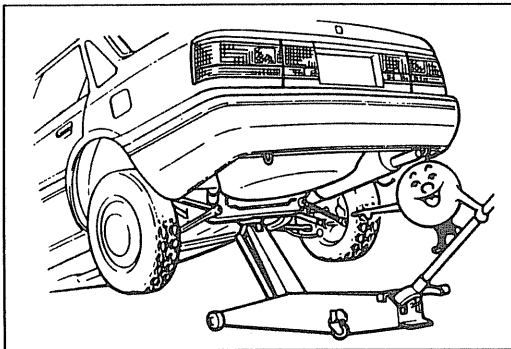

86U0GX-003

Safety stand positions:

On both sides of the body frame

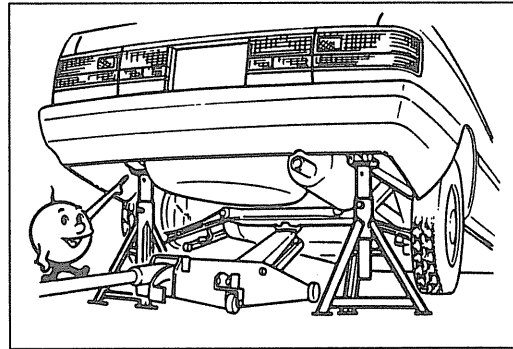

67U0GX-003

VEHICLE LIFT (2-SUPPORT TYPE) POSITIONS

FRONT END

Frame

Side sills (front)

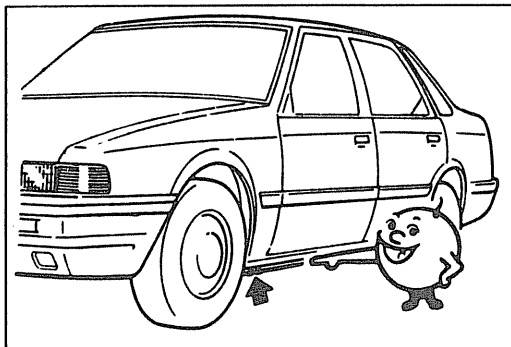

47U0GX-020

REAR END

Frame

Side sills (rear)

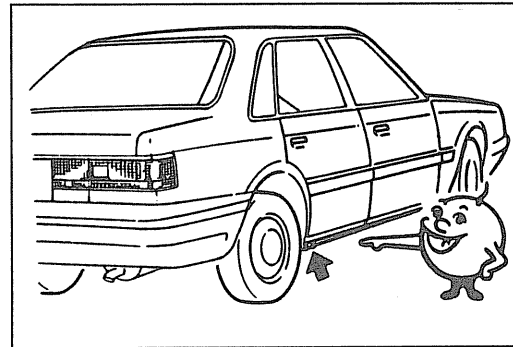

47U0GX-021

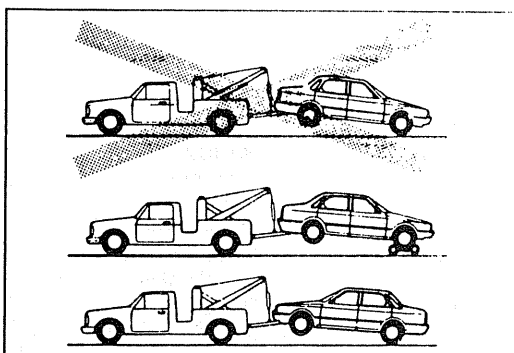

16UGIX-004

TOWING

Proper lifting or towing procedures are necessary to prevent damage to the vehicle during any towing operation. State and local laws applicable to vehicles in tow must be followed.

With either automatic or manual transaxle, release the parking brake, place the selector lever (or shift lever) in neutral and set the ignition key in the "ACC" position. As a general rule, towed vehicles should be pulled with the driving wheels off the ground.

If excessive damage or other conditions prevent towing the vehicle with the driving wheels off the ground, use wheel dollies.

Caution

- Do not tow the vehicle backward with driving wheels on the ground.
- This may damage the transaxle internal parts.
- Do not start or run the engine while vehicle is being towed.

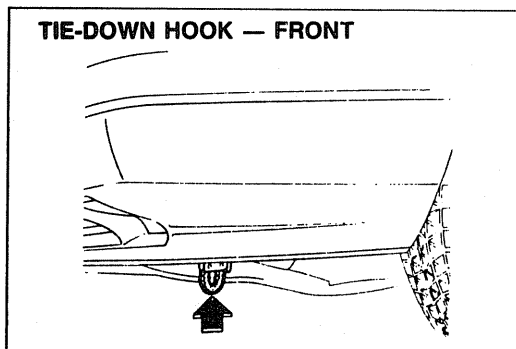

86UJGX-007

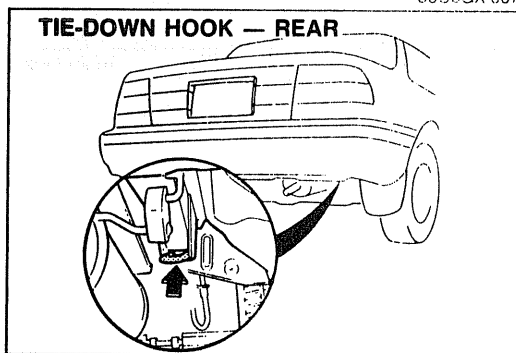

Caution

- Do not use the hook loops under the front and rear of vehicle for towing purposes. These hook loops are designed ONLY for transport tie-down. If tie-down hook loops are used for towing, front/rear skirt and bumper will be damaged.

IDENTIFICATION NUMBER LOCATIONS

VEHICLE IDENTIFICATION NUMBER

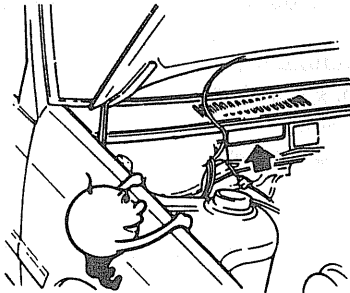

ENGINE MODEL AND NUMBER

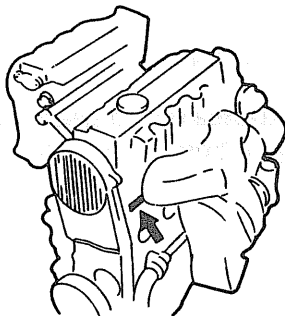

06UGIX-009

UNITS

N-m (m-kg or cm-kg)	Torque
ft-lb or in-lb)	Torque
rpm	Revolutions per minute
A	Ampere(s)
V	Volt(s)
Ω	Ohm(s) (resistance)
kPa (kg/cm ² psi)	Pressure (usually positive)
mmHg (in Hg)	Pressure (usually negative)
W	Watt
mm (in)	Length
liters (US qt, Imp qt)	Volume
oz	ounce

96U0GX-002

ABBREVIATIONS

ABDC	After bottom dead center
A/C	Air conditioner
ACC	Accessories
ADD	Additional fan
ATDC	After top dead center
ATX	Automatic transaxle
ATF	Automatic transaxle fluid
ABS	Anti-lock brake system
BBDC	Before bottom dead center
BTDC	Before top dead center
EX	Exhaust
EC-AT	Electronically controlled automatic transaxle
ESPS	Engine speed sensing power steering
ECPS	Electronically-controlled power steering
HLA	Hydraulic Lash Adjuster
IG	Ignition
IN	Intake
IC	Integrated circuit
INT	Intermittent
LH	Left hand
M	Motor
MTX	Manual transaxle
OFF	Switch off
ON	Switch on
PCV	Positive crankcase ventilation
P/S	Power steering
P/W	Power window
RH	Right hand
SST	Service special tools
ST	Start
SW	Switch
2WS	2-wheel steering

16UGIX-002

CAUTION**INSTALLATION OF A MOBILE TWO-WAY RADIO SYSTEM**

If a mobile two-way radio system is installed improperly, or if a wrong type is used, the Fuel Injection system and other systems may be affected.

When car is equipped with a mobile two-way radio system, observe the following precautions.

1. Install the antenna at the farthest point from the control unit.
2. Keep the antenna feeder as far away from the control unit harness as possible.
(at least 30 cm (11.8 in))
3. Insure that the antenna and feeder are properly adjusted.
4. Do not install a powerful mobile two-way radio system.

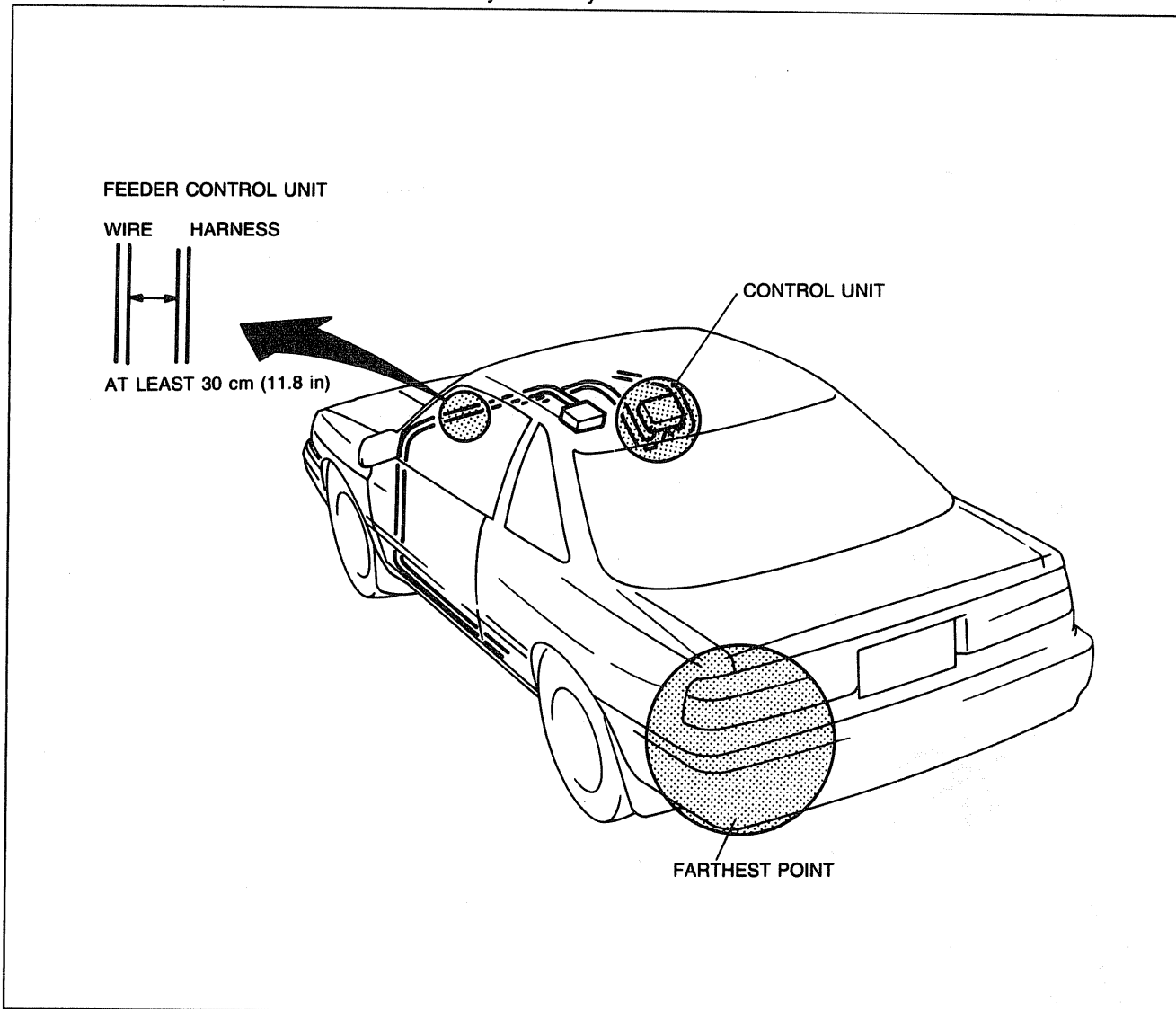

16UGIX-005

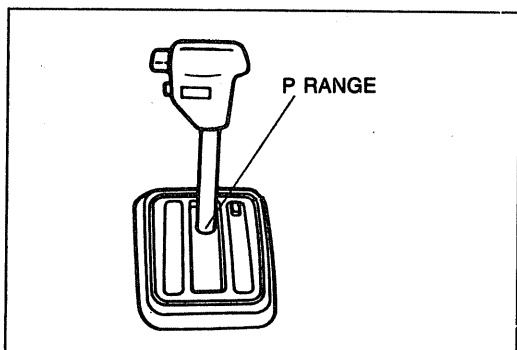

03UGIX-005

REMOVAL OF IGNITION KEY ON AUTOMATIC TRANSAXLE MODEL

The selector lever must be in P (PARK) to turn the ignition key to the OFF position. If the switch seems to be off but the key cannot be removed, the switch may still be in the ACC position, or the selector lever may not be in P (PARK). Shift the selector lever to P (PARK), and turn the ignition key to the LOCK position. The key should now be free for removal.

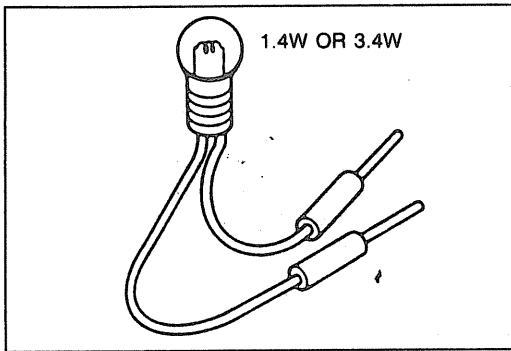

ELECTRICAL TROUBLESHOOTING TOOLS

Test Light

The test light, as shown in the figure, uses a 12V bulb. The two lead wires should be connected to probes. The test light is used for simple voltage checks and for checking for short circuits.

Caution

- When checking the control unit, never use a bulb over 3.4W.

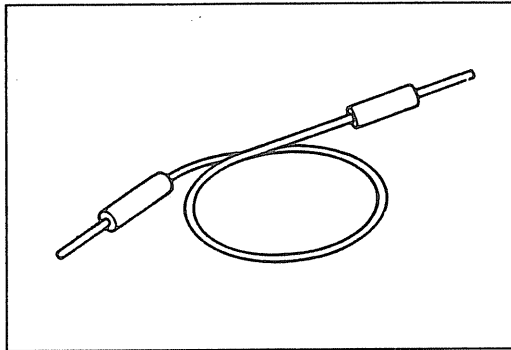

Jumper Wire

The jumper wire is used for testing by shorting across switch terminals and ground connections.

Caution

- Do not connect a jumper wire from the power source line to a body ground; this may cause burning or other damage to harnesses or electronic components.

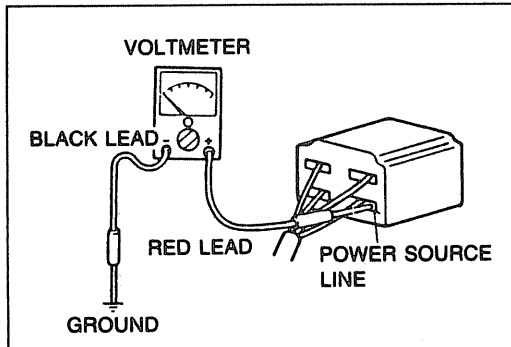

Voltmeter

The DC voltmeter is used to measure circuit voltage. A voltmeter with a range of 15V or more is used by connecting the positive (+) probe (red lead wire) to the point where voltage is to be measured and the negative (-) probe (black lead wire) to a body ground.

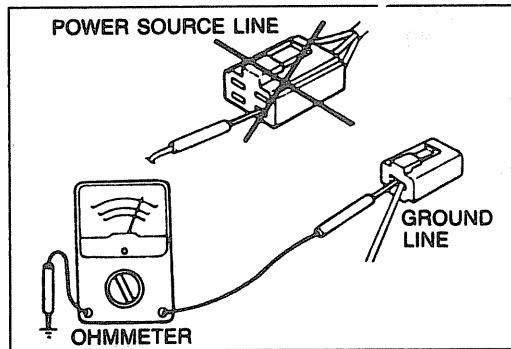

Ohmmeter

The ohmmeter is used to measure the resistance between two points in a circuit and also to check for continuity and diagnosis of short circuits.

Caution

- Do not attempt to connect the ohmmeter to any circuit to which voltage is applied; this may burn or otherwise damage the ohmmeter.

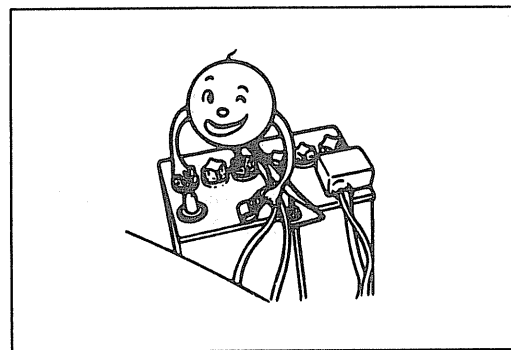

CAUTION WITH ELECTRICAL PARTS

Battery Cable

Before disconnecting connectors or replacing electrical parts, disconnect the negative battery cable.

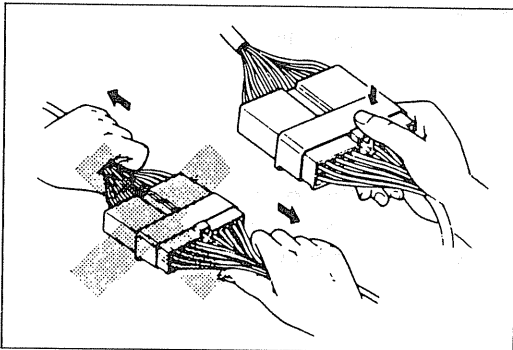

9MUGIX-023

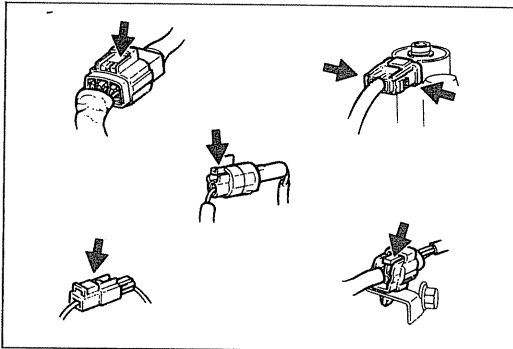

9MUGIX-024

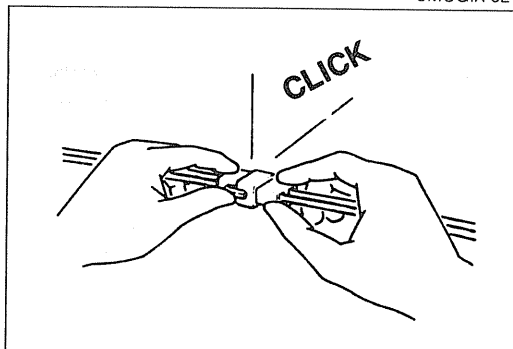

9MUGIX-025

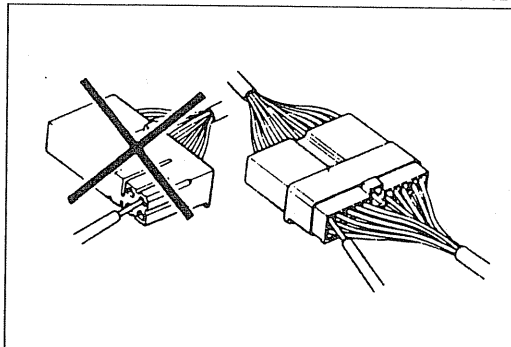

9MUGIX-026

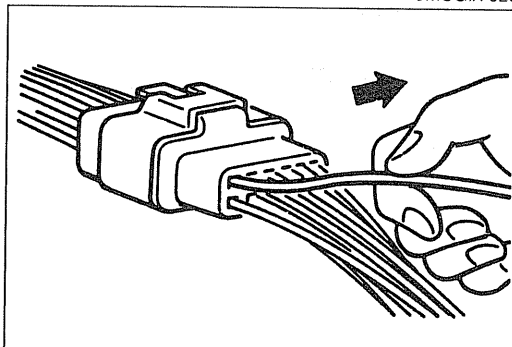

9MUGIX-027

Connectors Removal of connector

Never pull on the wiring harness when disconnecting connectors.

Connectors can be removed by pressing or pulling the lock lever as shown.

Locking of connector

When locking connectors, make sure to listen for a click that will indicate they are securely locked.

Inspection

When a tester is used to check for continuity or to measure voltage, insert the tester probe from the wire harness side.

Terminals Inspection

Pull lightly on individual wires to check that they are secured in the terminal.

CAUTION

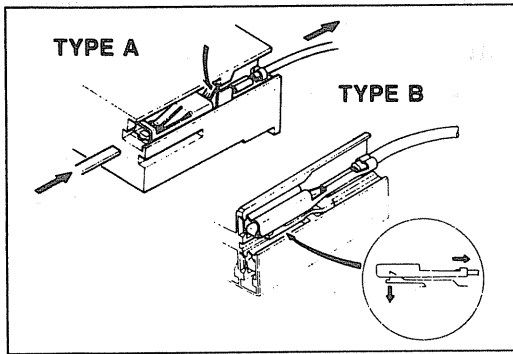

16UGIX-007

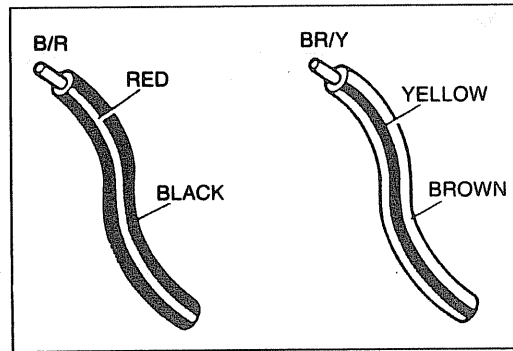
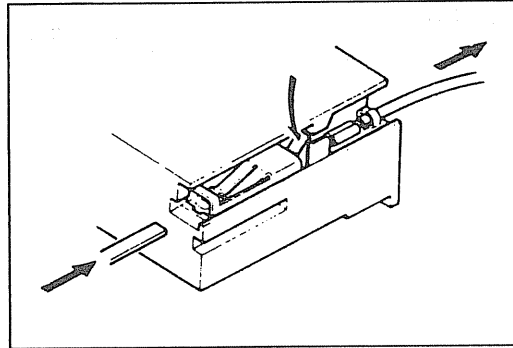

9MUGIX-029

Replacement of terminals

Use the appropriate tools to remove the terminal as shown. When installing the terminal, be sure to insert it until it locks secure.

< Female >

Insert a thin piece of metal from the terminal side of the connector, and then, with the terminal locking tab pressed down, pull the terminal out from the connector.

< Male >

Same as the female type.

Wiring Harness

Wiring color codes

Two-color wires are indicated by a two-color code symbol. The first letter indicates the base color of the wire and the second the color of the stripe.

CODE	COLOR	CODE	COLOR
B	Black	O	Orange
BR	Brown	P	Pink
G	Green	R	Red
GY	Gray	V	Violet
L	Blue	W	White
LB	Light Blue	Y	Yellow
LG	Light Green	—	—

Sensors, Switches, and Relays

Handle sensors, switches, and relays carefully. Do not drop them or strike them against other parts.

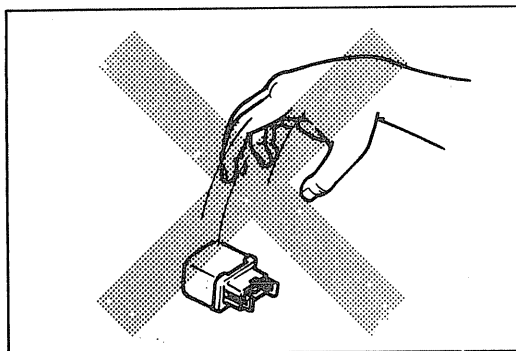

9MUGIX-030

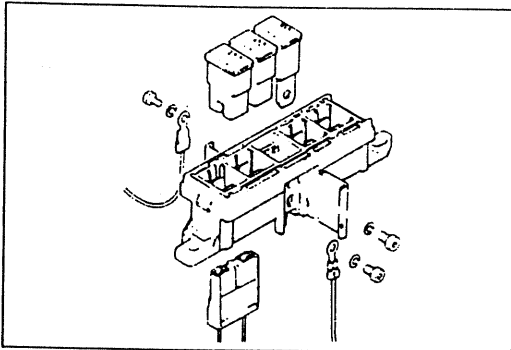

06UGIX-011

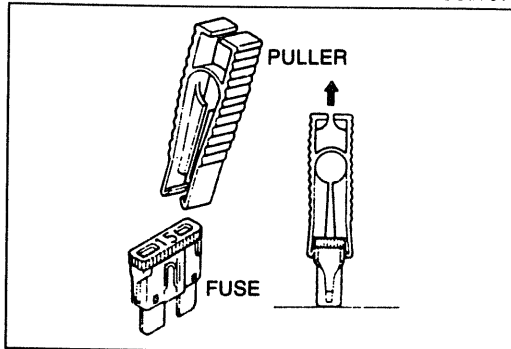

9MUGIX-032

Fuse Replacement

1. When replacing a fuse, be sure to replace it with one of specified capacity.
If a fuse again fails after it has been replaced, the circuit probably has a short circuit and the wiring should be checked.
2. Be sure the negative battery terminal is disconnected before replacing a main fuse (80A and 100A).
3. When replacing a pullout fuse, use the fuse puller supplied in the fuse box cover.